

1800W/1950W/2100W 双向 AC/DC 电源模块

产品特点

- ◆ 全数字控制电源
- ◆ 整流-并网逆变能量双向流动
- ◆ 模块化设计，支持并联扩容
- ◆ 双方向高效率
- ◆ 双方向高功率因数，低谐波电流
- ◆ 正反向自主判断
- ◆ 正反向快速切换
- ◆ 数字通信接口，完善的远程控制和信号上报功能
- ◆ 6kV 浪涌保护能力
- ◆ 10kA 防雷能力
- ◆ 良好的电磁兼容性，满足 EN55032 等国际标准
- ◆ 5000 米海拔高度设计
- ◆ 高温高湿环境设计
- ◆ 完善的故障保护功能
- ◆ 已通过 CE 认证，可通过 UL、TUV、CCC 认证



主要市场和应用：分容/储能等领域



气性能指标 (AC/DC 正向工作)

类别	指标名称	参数
输入特性	输入电压范围	176-264 Vac
	输入电压频率	50/60 ± 3Hz
	启动冲击电流	<11A @230Vac
	输入电流	<11A @230Vac
	功率因数	>0.99 @230Vac,满载
	电流谐波	<3% @230Vac,满载
输出特性	输出电压	PA-1800-12-A: 12V PA-1950-13-A: 13V PA-2100-14-A: 14V
	输出电流	150A
	最大输出功率	PA-1800-12-A: 1800W PA-1950-13-A: 1950W PA-2100-14-A: 2100W
	整流效率	89%Max
	稳压精度 (含初始精度、源调整率、负载调整率)	±0.5%

	温度系数	$\pm 0.02\% / ^\circ\text{C}$
	工频纹波	<100mV
电气性能指标 (DC/AC 反向工作)		
类别	指标名称	参数
输入特性	输入电压稳压点	PA-1800-12-A: 13Vdc PA-1950-13-A: 14Vdc PA-2100-14-A: 15Vdc
	输入电流	110A MAX
	最大输入功率	PA-1800-12-A: 1430W PA-1950-13-A: 1540W PA-2100-14-A: 1650W
输出特性	并网电压范围	176-264 Vac
	并网电压频率	50/60 \pm 3Hz
	并网电流	<8A @230Vac
	并网功率因数	>0.99 @230Vac, 满载
	并网电流谐波	<3% @230VAC, 满载
	效率	89%Max

其他电气指标		
类别	指标名称	参数
正反向切换	直流侧切换点	PA-1800-12-A: 12.6V PA-1950-13-A: 13.6V PA-2100-14-A: 14.6V
	切换速度	50us
对外通信	通信接口	CAN 总线
	上报信号	正反向信息
		各种保护信息
		电压电流信息
接收信号	开关机信号	

其他相关指标		
类别	指标名称	参数
工作环境	工作温度	-10 $^\circ\text{C}$ ~ 45 $^\circ\text{C}$
	储存温度	-40 $^\circ\text{C}$ ~ 70 $^\circ\text{C}$
	相对湿度	5% ~ 95%

	海拔高度	5000 米
	MTBF 预计	>250k 小时, 35℃, 满载
	引用标准	Telcordia SR_332
保护功能	孤岛保护	有
	交流侧欠压保护	<170Vac; 保护模式: 可恢复
	交流侧过压保护	>270Vac; 保护模式: : 可恢复
	直流侧限流	正向限流点: 151A; 保护模式: 恒流 反向限流点: 111A; 保护模式: 恒流
	直流侧短路保护	保护模式: 可恢复
	风扇故障保护	保护模式: 可恢复 (关机前 3 秒可查询保护状态)
	过温保护	保护模式: 可恢复 (关机前 3 秒可查询保护状态)
其它功能	风扇调速	有 (抽风)
	并联功能	有 (需通过四位拨码设置地址)
	并联后直流侧不均流度	<5%
	指示灯状态	故障: 红色 AC/DC 正向工作: 蓝色 DC/AC 反向工作: 绿色
电磁兼容性	传导干扰	EN55032 Class A
	辐射干扰	EN55032 Class A
	电流谐波	EN61000-3-2, A 类设备
	电压波动及闪烁	EN61000-3-2, A 类设备
	浪涌	共模: 6kV; 差模: 6kV
	电快速瞬变脉冲群	YD/T1082, 2kV
	雷击	共模: 10KA; 差模: 10KA
	输入电压暂降、中断与缓变	EN61000-4-11, ETSI EN 301 489
	静电放电抗干扰性	EN61000-4-2, 空气放电 8kV, 接触放电 6kV
	传导抗扰性	EN61000-4-6, EN 55024, ETSI EN 300 386, 3V
	辐射抗扰性	EN61000-4-3, ETSI EN 300 386, 80M~800MHz 3V/m, 800M~960MHz 10V/m, 960M~1GHz 3V/m, 1.4G~2GHz 10V/m, 2G~2.7GHz 3V/m, 80% AM
外形尺寸		333 × 141.4 × 45mm
端子螺钉最大扭矩(lbf.in)		交流端子 (M3) : 7 直流端子 (M5) : 13

产品外观及接口图

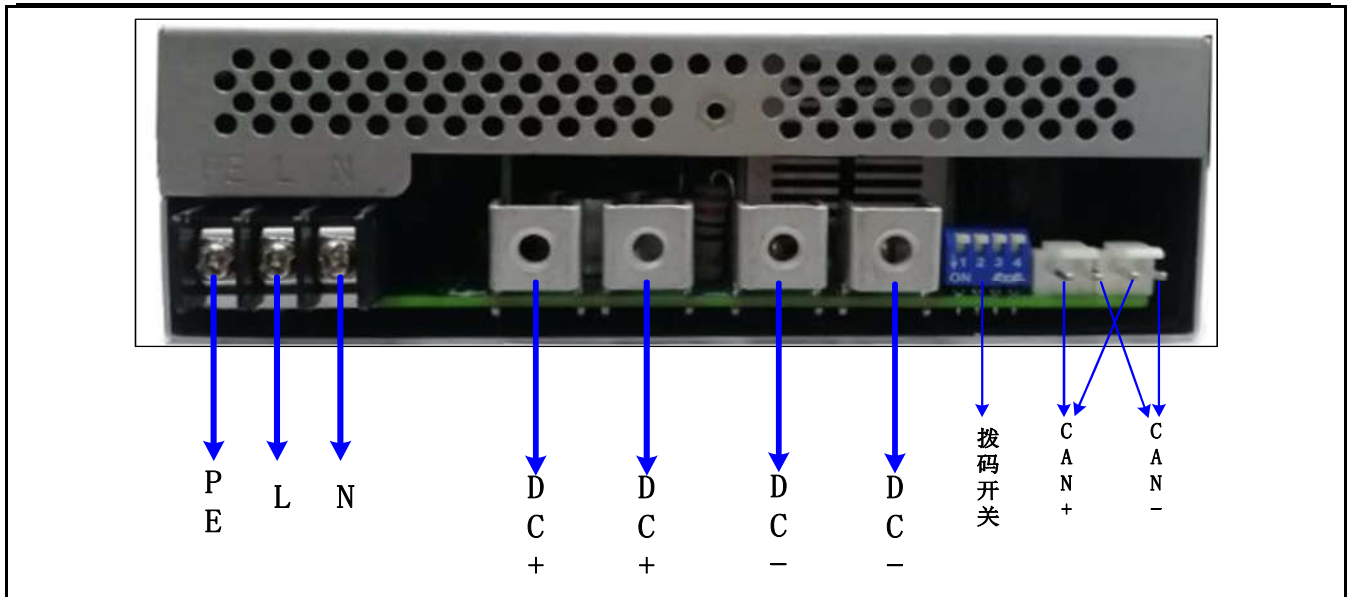

产品并联使用接线及说明

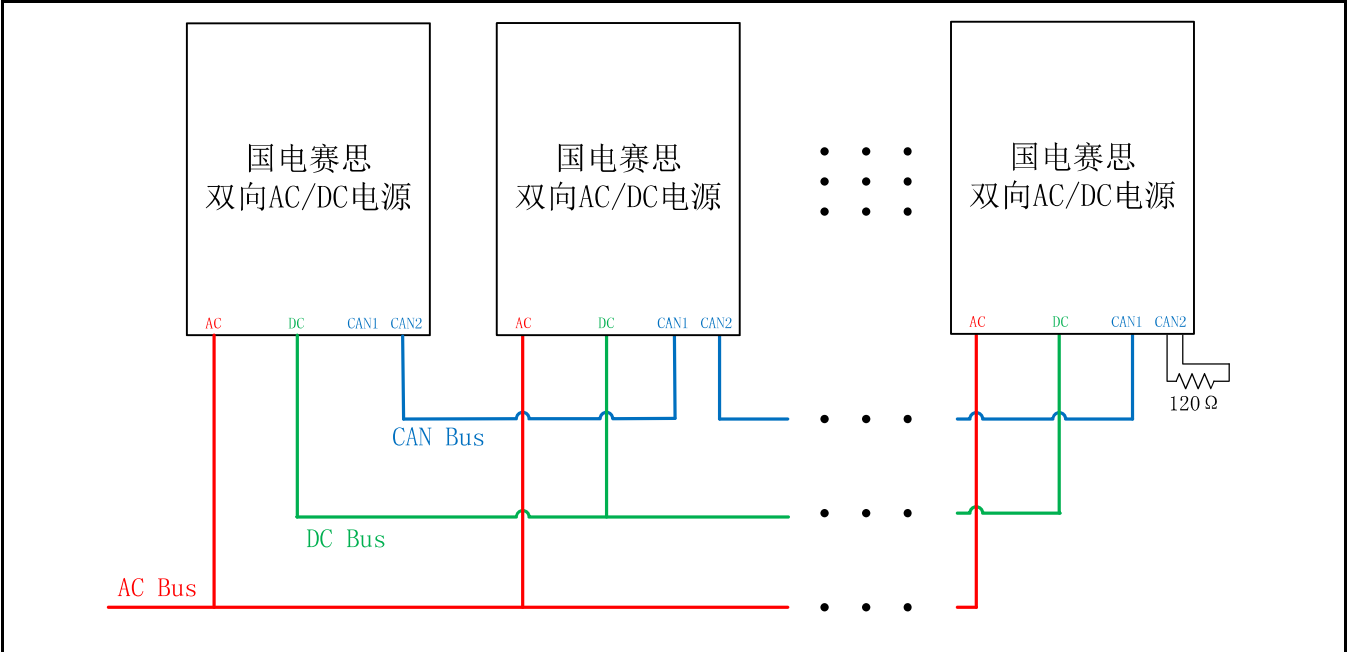

端口	连接方式	说明
AC 侧	市电交流 AC 侧进行并联，接入电网	L: 火线; N: 零线; PE: 地线
DC 侧	直流 DC 侧并联，构成直流母线	DC+: 直流电压正极; DC-: 直流电压负极
CAN 通信	CAN 通讯之间进行级联，同时在任意一组 CAN+ 与 CAN- 间接入 120 Ω 电阻	CAN+: CAN 通讯高电平; CAN-: CAN 通讯低电平
拨码开关	并联使用时，每台电源的拨码开关地址设置需不同	拨码开关由 4 位组成，采用 BCD 码定义模式，可形成 0~15 共 16 种地址。

产品使用注意事项

	应用环境问题	建议
维护注意事项	灰尘积累阻挡风道/风扇	增加系统防尘网并定期清理
	酸性/硫化/潮湿环境腐蚀线路	设备尽可能远离恶劣环境，尤其是含有酸性气体、硫化气体等空间场所。
	系统散热设计不良/热风回流	进行系统热仿真，选择合适的系统散热风扇，合理设计风道，避免热风回流。
DC/DC 过压保护点设置	客户系统 DC/DC 端需设置合理的反向工作动态过压保护点，过压保护点设定值应小于 18Vdc	

产品外形及装配尺寸图：

NOTES:

1. 单位: MM; 投影: 第一视角

UNIT:MM; PROJECTION: FIRST ANGLE;

2. 尺寸公差: $\pm 0.5mm$;

DIMENSIONS TOLERANCE: $\pm 0.5mm$;

3. 标记 'K' 的孔 (M3) 是安装孔。安装螺钉在壳体内部的部分，其长度不可大于 4.5MM。

THE HOLES MARKED 'K' ARE MOUNTING HOLES (M3). THE LENGTH OF MOUNTING SCREWS IN HOUSING PART SHOULD BE NO LONGER THAN 4.5MM.

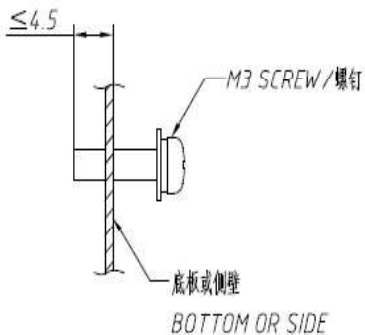

K处螺钉使用尺寸图

INSTALLATION DIMENSIONS OF SCREWS AT K

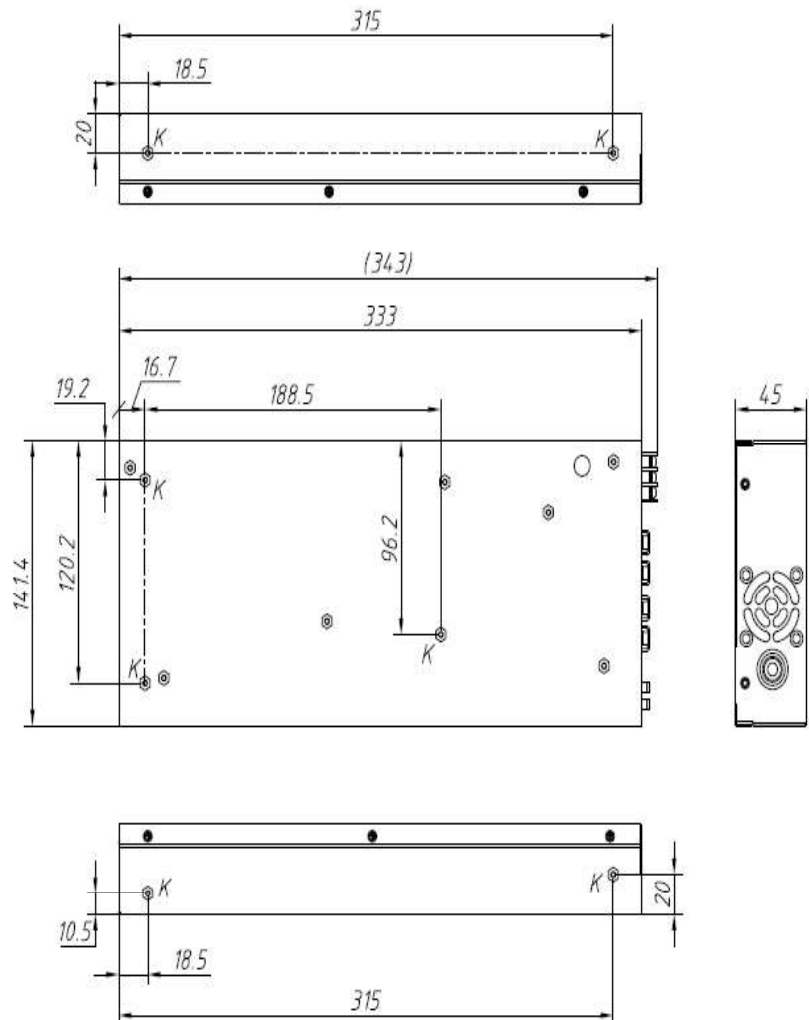

1800W/1950W/2100W Bidirectional AC/DC Converter

Main features

- ◆ Digital control
- ◆ Rectifier and grid connected inverter
- ◆ Operate in parallel is available
- ◆ High efficiency
- ◆ High power factor, and low harmonic current
- ◆ Automatic switch the energy direction
- ◆ Fast switch the energy direction
- ◆ Digital communication, perfect remote control and signal report
- ◆ 6kV surge protective capability
- ◆ 10kA lightning protective capability
- ◆ Good electromagnetic compatibility
- ◆ 5000 meter altitude applicability
- ◆ High temperature and high humidity applicability
- ◆ Perfect fault protective capability
- ◆ Satisfy the request of UL, TUV, CE, and CCC



Application

Energy bidirectional flow



Main electrical characteristic (AC to DC direction)

Type	Index	Rated
Input characteristic	Voltage Range	176-264 Vac
	Frequency Range	50/60 ± 3Hz
	Start-up Inrush Current	<11A @230Vac
	Input Current	<11A @230Vac
	Power Factor	>0.99 @230Vac, full load
	THDi	<3% @230Vac, full load
Output characteristic	Output Voltage	PA-1800-12-A:12V PA-1950-13-A:13V PA-2100-14-A:14V
	Output Current	150A MAX
	Maximum Output Power	PA-1800-12-A:1800W PA-1950-13-A:1950W PA-2100-14-A:2100W
	Efficiency	89% Max
	Precision of Voltage Regulation	±0.5%
	Temperature Coefficient	±0.02% / °C

	Power Frequency Ripple	<100mV
Main electrical characteristic (DC to AC direction)		
Type	Index	Rated
Input characteristic	Input Voltage	PA-1800-12-A: 13Vdc PA-1950-13-A: 14Vdc PA-2100-14-A: 15Vdc
	Input Current	110A MAX
	Maximum Input Power	PA-1800-12-A: 1430W PA-1950-13-A: 1540W PA-2100-14-A: 1650W
Output characteristic	Voltage Range	176-264 Vac
	Frequency Range	50/60 ± 3Hz
	Output Current	<8A @230Vac
	Power Factor	>0.99 @230Vac, full load
	THDi	<3% @230Vac, full load
	Efficiency	89%Max

Other electrical characteristic		
Type	Index	Rated
Direction Switch	Switch Point	PA-1800-12-A: 12.6V PA-1950-13-A: 13.6V PA-2100-14-A: 14.6V
	Switch Speed	50us
Communication	Port	CAN
	Report Signal	Direction
		Alarm Signal
		Rotate speed of fan
Remote Control	Turn-on and turn-off	

Other characteristic		
Type	Index	Rated
Environmental	Operation Temperature	-10°C ~ 45°C
	Storage Temperature	-40°C ~ 70°C
	Relative Humidity	5% ~ 95%
	Altitude	5000m
	MTBF	>250k hours, 35°C, full load
	Standard	Telcordia SR_332
Protection	Islanding Protection	Yes
	AC Under-voltage protection	<170Vac; Protect mode: Auto recovery
	AC Over-voltage protection	>270Vac; Protect mode: Auto recovery

	Over Current Protection	Protect Mode: Constant Current
	Fan Fault Protection	Protect mode: Auto recovery
	Over Temperature Protection	Protect mode: Auto recovery
Other Function	Speed Governing of Fan	Yes (Air out)
	Run in parallel	Yes(Must distribute different address for every power module through the dial switch)
	Unbalance Rate of DC Current Sharing	<5%
	Indicator lamp	Fault: Red AC to DC direction: Blue DC to AC direction: Green
EMC	Conducted Emission	EN55032 Class A
	Radiated Emission	EN55032 Class A
	Harmonic Current Emission	EN61000-3-2, A class equipment
	Voltage fluctuation and Flicker	EN61000-3-2, A class equipment
	Immunity to surges	L&N to PE: 6kV; L to N: 6kV
	Immunity to Electrical Fast Transient	YD/T1082, 2kV
	Immunity to lightning	L&N to PE: 10KA; L to N: 10KA
	Immunity to Voltage Dips and short interruptions	EN61000-4-11, ETSI EN 301 489
	Immunity to Electrostatic Discharge	EN61000-4-2, Air discharge 8kV, Contact discharge 6kV
	Immunity to Continuous Conducted Interference	EN61000-4-6, EN 55024, ETSI EN 300 386, 3V
	Immunity to Radiated Electric Fields	EN61000-4-3, ETSI EN 300 386, 80M~800MHz 3V/m, 800M~960MHz 10V/m, 960M~1GHz 3V/m, 1.4G~2GHz 10V/m, 2G~2.7GHz 3V/m, 80% AM
Sizes		333×141.4×45mm
Maximum Screw Torque (lbf.inch)		AC terminal (M3) : 7 DC terminal (M5) : 13

Interface Figure:

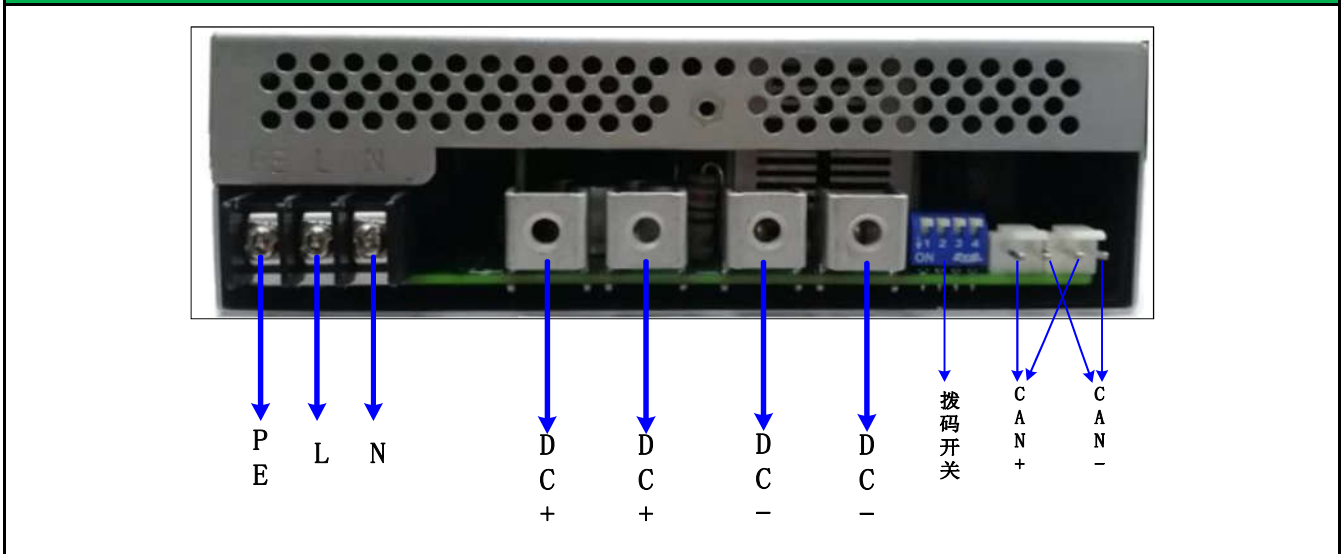

Parallel operation instructions

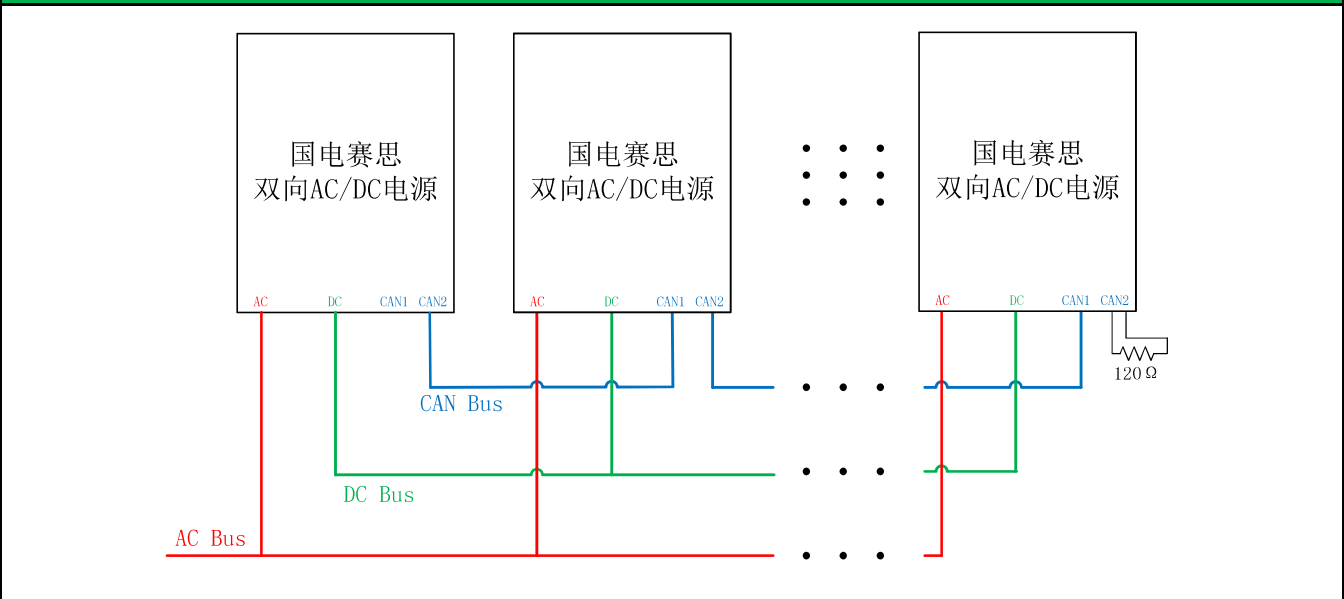

Port	Connection type	Instructions
AC terminal	The AC side is connected in parallel to the power grid.	L: Live wire; N: Neutral wire; PE: Protecting Earthing
DC terminal	DC side is parallel to form DC bus.	DC+:The positive pole of DC; DC-:The negative pole of DC
CAN communication	Connect the communication lines, and in any group CAN + and CAN indirectly into 120 Ω resistance	CAN+: High-level of CAN communication; CAN-: Low-level of CAN communication
Dial switch	In parallel, all dial switch addresses of power supply must be different.	The dial switch consists of four bits and can form a total of 16 addresses.

Precautions for use

	Application problems	Advice
Maintenance precautions	The duct/fan is blocked by dust	Add system dust-proof net and clean regularly
	Line corroded by acidic/sulfuretted/moist environment	Keep the equipment as far away from the bad environment as possible, especially contains acid gas, sulfide gas and other space places.
	The system has poor heat dissipation design/Hot air reflow	System thermal simulation. Choose the right system cooling fan. Design airway reasonably to avoid hot air reflow
DC/DC overvoltage protection point Settings	Set reasonable reverse working dynamic overpressure protection points. And the set value should be less than 18Vdc.	

Dimension Figure

NOTES:

1, 单位: MM; 投影: 第一视角

UNIT: MM; PROJECTION: FIRST ANGLE;

2, 尺寸公差: $\pm 0.5\text{mm}$;

DIMENSIONS TOLERANCE: $\pm 0.5\text{mm}$;

3, 标记'K'的孔(M3)是安装孔。安装螺钉在壳体内部的部分, 其长度不可大于4.5MM。

THE HOLES MARKED 'K' ARE MOUNTING HOLES (M3). THE LENGTH OF MOUNTING SCREWS IN HOUSING PART SHOULD BE NO LONGER THAN 4.5MM.

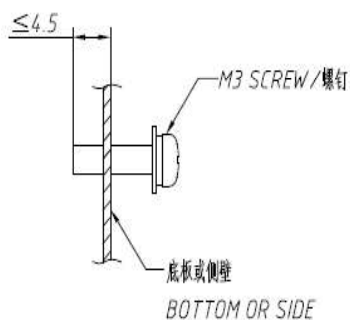

K处螺钉使用尺寸图

INSTALLATION DIMENSIONS OF SCREWS AT K

